

SIDE MOUNTING  
RAP-TIE  
APPLICATION

## Introduction

The Side Mounting Rap-Tie system (Rod Adjustable Plate Tie system) consists of a Plate (a vertically orientated, flat plate), a V-Tie™ (a V-shaped wire), and an Insulation Support (optional, but recommended). These individual components are shown in Figures 1, 2 and 3, respectively. The installed tie system is shown in the Cover Illustration and Figure 4.

Tensile and compressive lateral loads applied to the masonry veneer are transferred through the V-Tie™ to the Plate, which is fastened directly to the structural backing without any intervening material such as sheathing. The Plate is fastened to the side surface of a structural backing member such as a steel stud web, wood stud, or miscellaneous steel (see Cover illustration, and Figure 4). The holes along the outboard end of the Plate through which the V-Tie™ is inserted provide a positive connection, without the possibility of V-Tie™ disengagement during construction and in-service (in accordance with requirements in CSA A370, "Connectors for Masonry", and ACI 530/ASCE 5/TMS 402, "Building Code Requirements for Masonry Structures"), and permit up to 36 mm (1.4") of in-situ vertical adjustment so that a bed joint in the masonry veneer will always be coincident with the V-Tie™.

The Insulation Support, inserted over the end of the Plate and restrained by the V-Tie™, is optionally used to securely and mechanically fix cavity insulation in place.

## Introduction...cont.

Figure 1 Flat-Plate

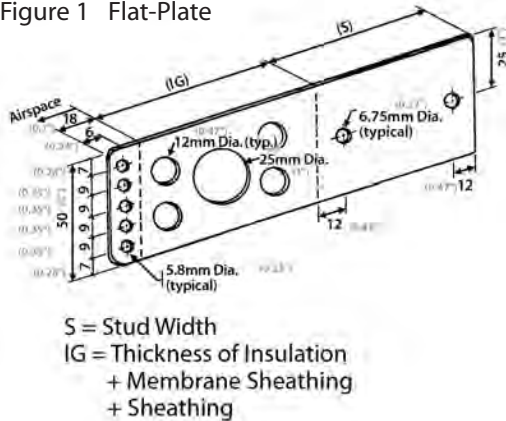

The Side Mounting Rap-Tie system can accommodate a range of insulation thicknesses from 0 to 102 mm (0 to 4"), and air space widths of 25 mm (1") and greater. The Plate has sufficient length to accommodate the thickness of the cavity insulation, and further extends 18 mm (0.7") into the air space to expose its leading edge and facilitate in-situ placement of the V-Tie™ and optional Insulation Support. The V-Tie™ is inserted through the appropriate hole along the leading edge of the Plate, coincident with the mortar bed joint of the masonry veneer, so as to extend horizontally and normally to the structural backing without reducing tie capacity. The legs of the V-Tie™ are positioned along the centreline of the veneer within the placement tolerances permitted by the building code having jurisdiction. Adjustment normal to the wall is facilitated by selecting an appropriate length of V-Tie™.

The Side Mounting Rap-Tie system has been engineered to eliminate many issues problematic for a multi-component tie. It offers positive restraint between tie components to prevent disengagement, reduced mechanical free play, limited deformation under load, and "side mounting," which places the fastener connecting the tie and structural backing in shear rather than direct tension. This fastener orientation, and the inboard position of the fastener within the wall system, provide a more desirable connection to the structural backing than surface-mounted tie systems which subject the fasteners to direct tension and generally higher moisture loads. Side mounting reduces the likelihood of corrosion at the fastener/structural member interface.

## Components and Specifications

**Flat-Plate:** The Flat-Plate (Figure 1) is manufactured from 16 gauge sheet steel (1.367 mm [0.0538"] minimum base steel thickness) and is available in both hot-dip galvanized finish and stainless steel. The weight of hot-dip galvanized finish is not less than 460 g/m<sup>2</sup>/side (1.5 oz/ft.<sup>2</sup>/side), and satisfies the requirements of CSA A370 (which references ASTM A123), ACI 530.1/ASCE 6/TMS 602 (which references ASTM A153, Class B) and the International Codes (which reference ASTM A153, Class B). The incorporation of holes through the mid-body of the Plate minimizes thermal conductivity through the tie system.

The Flat-Plate specification length, (S), refers to the actual width of the (steel) stud to which it is connected; and the specification length, (IG) refers to the actual thickness of the insulation plus sheathing membrane plus sheathing. The specification length, (S), should be the same dimension as the actual stud width; the inboard end of the Flat-Plate is intended to be installed flush with the interior flange face of the stud.

The overall length of the Flat-Plate is 18 mm (0.7") longer than the specification lengths (S + IG); this being the length of projection of the Flat-Plate into the air space. Specification length can vary to accommodate: standard stud width, (S), of 102 mm (4"), 152 mm (6") and 203 mm (8"); and thickness of insulation plus sheathing membrane plus sheathing, (IG), of 0 (0"), 28 (1.1"), 41 (1.6"), 54 (2.1"), 67 (2.6"), 79 (3.1"), 92 (3.6") and 105 mm (4.1"). Intermediate sizes are also available.

Holes having 12 mm and 25 mm diameter are punched through the mid-body of the Flat-Plate. When the Plate is mounted, these holes are located within the cavity insulation and minimize thermal conductivity through the tie system.

Two (2) 6.75 mm (0.27") diameter screw holes within length, (S), of the Flat-Plate provide for plate fastening to the structural backing member. Maximum screw size is #12.

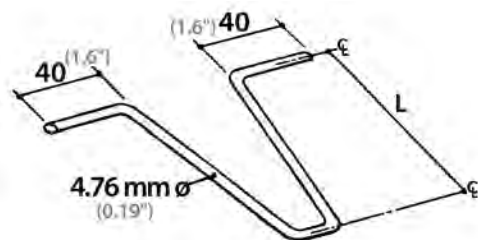

Figure 2 V-Tie™

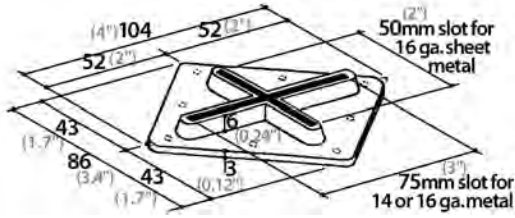

Figure 3 Insulation Support

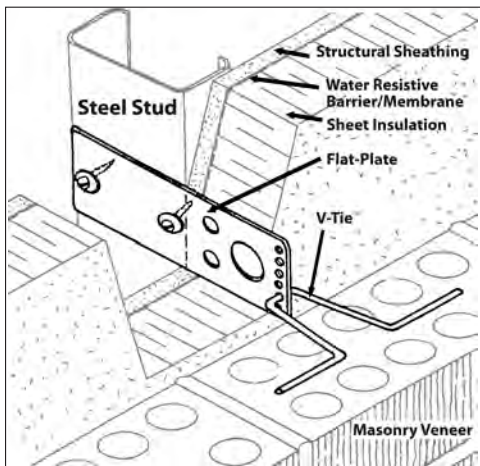

Figure 4 Side Mounting Rap-Tie™ System without Insulation Support

A series of five 5.8 mm (0.23") diameter holes are punched along the leading edge of the Flat-Plate to receive the V-Tie™.

**V-Tie™:** The V-Tie™ (Figure 2) is manufactured from 4.76 mm (0.19") diameter wire and is available in both hot-dip galvanized finish and stainless steel. The weight of the hot-dip galvanized finish is not less than 460 g/m<sup>2</sup> (1.5 oz/ft.<sup>2</sup>) and satisfies the requirements of CSA A370 (which references ASTM A123), ACI 530.1/ASCE 6/TMS 602 (which references ASTM A153, 458 g/m<sup>2</sup>) and the International Codes (which reference ASTM A153, Class B, 458 g/m<sup>2</sup>).

The V-Tie™ is available in a variety of standard lengths to accommodate different specified thicknesses of masonry veneer and design widths of air space. The V-Tie™ specification length, (L), should be selected to provide for placement of the legs of the V-Tie™ along the centreline of the masonry veneer. Varying lengths of V-Tie™, appropriately selected by the mason on the jobsite, facilitate in-situ adjustment normal to the structural backing where the constructed width of air space differs from the design width of air space (to accommodate construction tolerances). Standard lengths of V-Tie™ include 60 mm (2.4"), 80 mm (3.1"), 100 mm (3.9"), 120 mm (4.7"), 140 mm (5.5"), 160 mm (6.3"), 180 mm (7.1"), 200 mm (7.9"), 225 mm (8.9") and 250 mm (9.8"). For example, the 50 mm (2.4") V-Tie™ is used in a Side Mounting Rap-Tie system consisting of 25 mm (1") air space and 90 mm (3.5") masonry veneer.

**Insulation Support:** The Insulation Support (Figure 3) is manufactured from polyethylene. It is pressed by hand over the outboard end of the Flat-Plate tightly against the cavity insulation to prevent the insulation from separating from the structural backing/air barrier/sheathing membrane. The friction fit between the Insulation Support and the Flat-Plate restrains the insulation during construction which is commonly installed in advance of the exterior masonry veneer. Subsequent installation of the V-Tie™ sandwiches the Insulation Support between the insulation and the V-Tie™, thereby locking the Insulation Support in-place and ensuring a reliable and permanent insulation support system.

The Insulation Support is a standard component of the system, but it is optional where the insulation is otherwise supported, and not required where no insulation is placed within the cavity. Figure 4 shows the system without the Insulation Support.

## Structural Composite Action

In many applications, the Side Mounting Rap-Tie system is designed and used to simply transfer the incident lateral load from the exterior masonry wythe (the veneer) axially to the structural backing.

Alternatively, because of the vertical orientation of the Flat-Plate and its consequent rigidity, and because the (tie) fastener-to-stud connection is capable of resisting moment, vertical shear forces (as well as axial forces) can be resisted by the Side Mounting Rap-Tie system to provide composite action between the masonry veneer and the structural backing. The entire wall thickness, including both veneer and structural backing, thereby becomes effective in resisting lateral loads. Composite action increases system stiffness, reduces lateral deflections and increases lateral resistance. To consider composite action, the veneer system must be suitably designed; use the FERO Shear Truss program to evaluate forces in the assembly. A Side Mounting Rap-Tie can be used for retro-fitting masonry veneer systems where reducing lateral deflection of the steel stud structural backing is a required intervention.

# SIDE MOUNTING RAP-TIE

# Side Mounting Rap-Tie System Design Data

## Side Mounting Rap-Tie System Design Data (Canada)

Design Parameter	Design Data Side Mounted (i),(iii)	
1. Mechanical Free Play: <sup>(iii)</sup> (with FERO V-Tie™)	0.80 mm (max) (0.031")	
2. Serviceability at 0.45 kN (100 lbs) <sup>(iii)</sup>		
Deflection	0.11 mm (0.0043")	
Deflection + Mechanical Free Play	0.91 mm (max) (0.036")	
3. Factored Resistance ( $\phi P_{ult}$ ) <sup>(iv),(v),(vi)</sup>	3.69 kN [825 lbs.]	
4. Maximum Recommended Spacing: <sup>(vii)</sup>	Horizontal: 800 mm [32"]	Vertical: 600 mm [24"]

- (v) The stated tie factored resistance is based on the capacity of FERO tie components, and does not consider fastener resistance. A compatible fastener having an adequate factored resistance must be selected (by design in accordance with CSA A370-04).
- (vi) The factored resistance of the mortar pull-out or push-through for the V-Tie™ embedded at the centreline of 90 mm (3.5") brick veneer utilizing Type S or N mortar exceeds or equals the tabled factored resistance,  $\phi P_{ult}$ . Failure by pull-out/push-through of the mortar joint does not govern.
- (vii) Maximum recommended tie spacings are the maximum spacings permitted by CSA S304.1-04, *Design of Masonry Structures*. For a particular design, the actual tie spacings are calculated such that the factored resistance of the tie,  $\phi P_{ult}$ , equals or exceeds the effect of factored loads. See S304.1-04 for the design of masonry veneer systems.

## Side Mounting Rap-Tie System Design Data (U.S.)

Design Parameter	Design Data Side Mounted (i),(iii)	
1. Mechanical Free Play: <sup>(iii)</sup> (with FERO V-Tie™)	0.031" (max) 0.80 mm	
2. Serviceability at 100 lbs (0.45 kN) <sup>(iii)</sup>		
Deflection	0.0043" (0.11 mm)	
Deflection + Mechanical Free Play	0.036" (max) (0.91 mm)	
3. Nominal Strength <sup>(iv),(v),(vi),(vii),(ix)</sup>	920 lb [4.09 kN]	
4. Recommended Design Load <sup>(iv),(v),(vi),(vii),(ix)</sup>	410 lb [1.82 kN]	
5. Maximum Recommended Spacing: <sup>(vii)</sup>	Horizontal: [32"] 813 mm	Vertical: [18"] 457 mm

- (iv) The nominal strength of the Side Mounting Rap-Tie system is determined by test and is reported as the average ultimate strength of the tie samples. In accordance with ACI 530/ASCE 5/TMS 402, using Strength Design, a suitable strength-reduction factor must be applied to the nominal strength to determine the tie design strength. Similarly, under Allowable Stress Design, an appropriate safety factor must be applied to determine an allowable load value. The tabled "Recommended Design Load" reflects a safety factor of 2.25 (that is, 75% of 3.0). [See also Note (v) when assigning a strength-reduction factor to the nominal strength].
- (v) The stated nominal strength and the recommended design load do not consider fastener capacity. A compatible fastener having an adequate strength must be selected (by design, in accordance with ACI 530.1/ASCE 6/TMS 602).
- (vi) The nominal strength (and corresponding recommended design load) of the mortar pull-out or push-through for the V-Tie™ embedded at the centerline of 3.5" (90 mm) brick veneer utilizing Type M, S or N mortar exceeds or equals the tabled nominal strength (and recommended design load). Failure by pull-out/push-through of the mortar joint does not govern.
- (vii) Maximum recommended tie spacings are the maximum spacings permitted by ACI 530/ASCE 5/TMS 402 using prescriptive requirements for anchored masonry veneer. The prescriptive requirements in ACI 530/ASCE 5/TMS 402 further limit a tie tributary area to not more than 2.67 ft.<sup>2</sup> (0.25 m<sup>2</sup>) wall area [with reduced areas for high Seismic Design Categories and in areas of high winds] unless the veneer is alternatively designed using a rational, engineered method (termed "Alternative Design of Anchored Masonry Veneer"). Where an Alternative Design is used, the required tie spacing may be calculated such that the design strength of the tie equals or exceeds the required strength. See ACI 530/ASCE 5/TMS 402 for the design of masonry veneer systems.
- (viii) The Side Mounting Rap-Tie system satisfies ACI 530/ASCE 5/TMS 402 requirements for minimum wire size of W1.7 (MW11) and for ends bent to form a minimum 2 in (50.8 mm) extension.
- (ix) ACI 530/ASCE 5/TMS 402 requires joint reinforcement in masonry veneer in high Seismic Design Categories to be mechanically attached to the masonry tie.

Design data for the Side Mounting Rap-Tie system are reported separately for Canada and the United States in the following tables because design methods and requirements for masonry ties and their uses differ between their respective codes and standards.

Notes:

- (i) These design data are based on connector testing in accordance with CSA A370-04, *Connectors for Masonry*, with no surcharge and with test samples having the following configuration: 76 mm [3"] cavity (with configuration for 25 mm [1"] air space); standard FERO V-Tie™; and V-Tie™ engaged into Plate at position of maximum vertical adjustment; no insulation or gypsum board present. Smaller cavity widths and/or the addition of insulations providing lateral support to the tie Plate will increase the tabled factored resistance of the tie and reduce tie deflection.
- (ii) These design data reflect both the windward (compression) and leeward (tension) capacities of the Side Mounting Rap-Tie system, with the governing values listed.
- (iii) The Side Mounting Rap-Tie system satisfies the limiting requirements for serviceability (tie displacement and mechanical free play) in CSA A370-04. Tabled mechanical free play is for stainless steel components. The mechanical free play for hot-dip galvanized components is less.
- (iv) The ultimate strength of the Side Mounting Rap-Tie system,  $P_{ult}$ , is determined in accordance with CSA A370-04 and is calculated by multiplying the average tie strength established by testing by (1 - 1.64 cov). The factored resistance of the tie system ( $\phi P_{ult}$ ) is calculated using the Limit States Design procedures of CSA A370-04.

Notes:

- (i) These design data are based on connector testing in accordance with CSA A370-04, *Connectors for Masonry*, with no surcharge and with test samples having the following configuration: 76 mm [3"] cavity (with configuration for 25 mm [1"] air space); standard FERO V-Tie™; and V-Tie™ engaged into Plate at position of maximum vertical adjustment; no insulation or gypsum board present. The test method for ties in CSA A370-04 is comparable to that of ASTM E754, *Test Method for Pullout Resistance of Ties and Anchors Embedded in Masonry Mortar Joints*, and provides similar and more conservative results. Smaller cavity widths and/or the addition of insulations providing lateral support to the Flat-Plate will increase the nominal strength of the tie and reduce tie deflection. Prescriptive requirements for anchored masonry veneer under ACI 530/ASCE 5/TMS 402 limit the cavity to a maximum width of 4-1/2" (114 mm) unless the veneer is alternatively designed using a rational, engineered design method (termed "Alternative Design of Anchored Masonry Veneer").
- (ii) These design data reflect both the windward (compression) and leeward (tension) capacities of the Side Mounting Rap-Tie system, with the governing values listed.
- (iii) The Side Mounting Rap-Tie system satisfies the 1/16" (1.6 mm) maximum permissible clearance between connecting parts required by ACI 530/ASCE 5/TMS 402. Tabled mechanical free play is for stainless steel components. The mechanical free play for hot-dip galvanized components is less.

Fero Corporation

15305 - 117 Avenue, Edmonton, Alberta T5M 3X4  
Phone: (780) 455-5098 Fax: (780) 452-5969  
www.ferocorp.com info@ferocorp.com

Patent Pending  
©2000 Fero Corporation

