

SLOTTED STUD TIE (TYPE II)

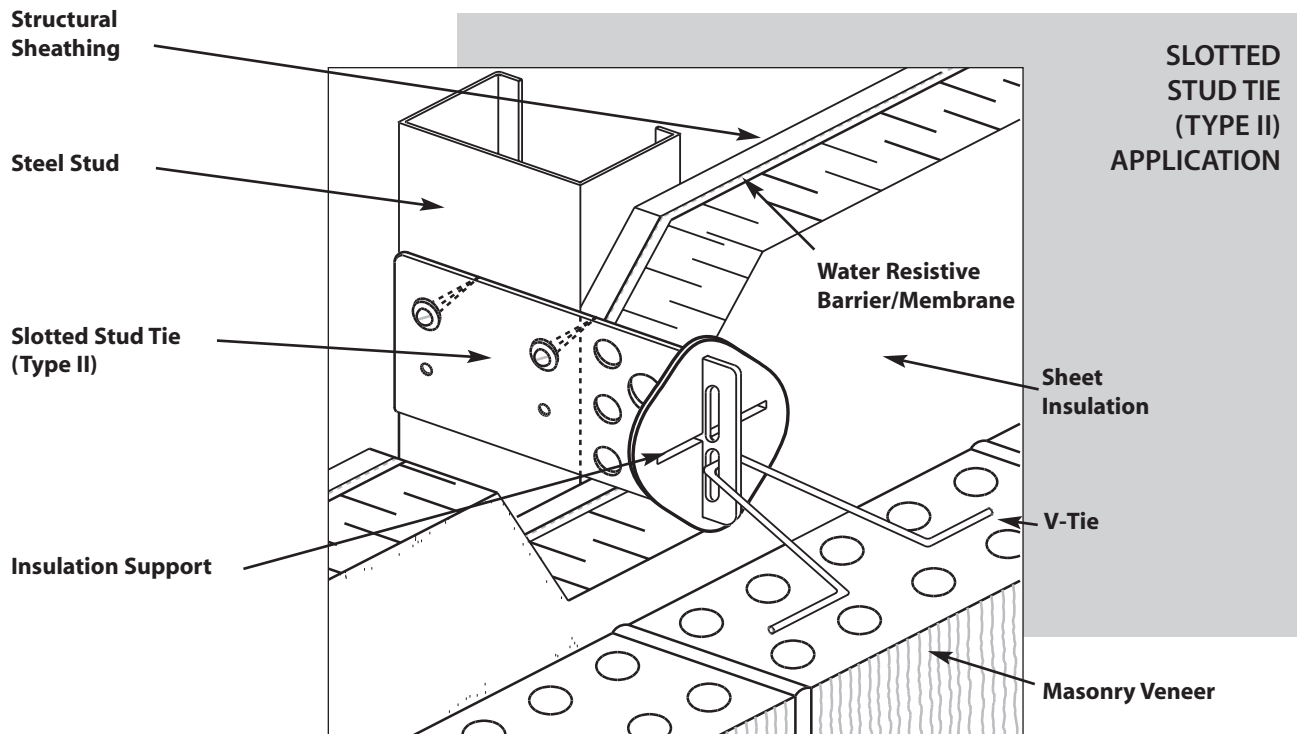
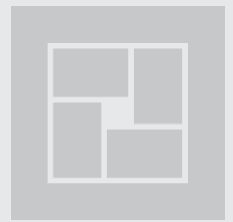

Introduction

The Slotted Stud Tie (Type II) system consists of a Slotted Stud Plate (Type II) (which is a vertically oriented plate), a V-Tie™ (a V-shaped wire), and an Insulation Support (a polyethylene retainer). Individual components are shown in Figures 1, 2 and 3; the assembly is shown in Figure 4; and the installed tie system is illustrated in Figure 5.

The Stud Plate is fastened to a side surface of structural backing members such as steel stud, wood stud, or miscellaneous steel (see Cover Illustration, and Figure 5). The V-Tie™ is inserted through either of the two vertical slots along the outboard end of the Slotted Block Plate. Lateral loads applied to the masonry veneer are transferred through the V-Tie™ to the Slotted Stud Plate which is fastened directly to the structural backing without any intervening material such as sheathing. The closed vertical slot provides a positive connection without the possibility of V-Tie™ disengagement during construction and in-service (in accordance with requirements in CSA A370 and ACI 530.1/ASCE 6/TMS 602). The double slots permit up to 60 mm (2.4") of in-situ vertical adjustment so that a bed joint in the masonry veneer will always be coincident with the V-Tie™ regardless of the vertical placement of the Stud Plate along the supporting structural member. Each vertical slot accommodates a 25 mm (1") in-service vertical differential movement between the masonry veneer and the structural backing.

When compared to the Slotted Stud Tie (Type I) which uses a single slot rather than two shorter slots, the Slotted Stud Tie (Type II) offers greater vertical adjustability, reduced displacement, and higher strength. It is intended for use in masonry veneer/steel stud wall systems where comparatively larger differential movement between the veneer and steel stud is expected, such as high walls or multi-storey buildings with full height veneer.

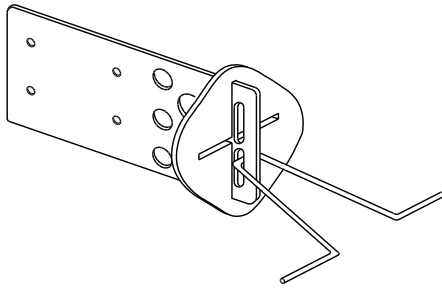

Figure 4 Slotted Stud Tie (Type II)

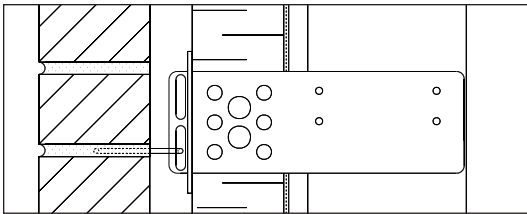

Figure 5 An installation wall section

Structural Action

satisfies the requirements of CSA A370 (which references ASTM A123), ACI 530.1/ASCE 6/TMS 602 (which references ASTM A153, 458 g/m²) and the International Codes (which reference ASTM A153, Class B, 458 g/m²).

The V-Tie™ is available in a variety of standard lengths to accommodate different specified thicknesses of masonry veneer and design widths of air space. The V-Tie™ specification length, (L), should be selected to provide for placement of the legs of the V-Tie™ along the centreline of the masonry veneer. Varying lengths of V-Tie™, appropriately selected by the mason on the jobsite, facilitate in-situ adjustment normal to the structural backing (to accommodate construction tolerances) where the constructed width of air space differs from the design width of air space. Standard lengths of V-Tie™ include 60 mm (2.4"), 80 mm (3.1"), 100 mm (3.9"), 120 mm (4.7"), 140 mm (5.5"), 160 mm (6.3"), 180 mm (7.1"), 200 mm (7.9"), 225 mm (8.9") and 250 mm (9.8"). For example, the 60 mm (2.4") V-Tie™ is utilized in the Slotted Stud Tie (Type II) system consisting of 25 mm (1") air space and 90 mm (3.5") masonry veneer.

Insulation Support. The Insulation Support (Figure 2) is manufactured from polyethylene. It is pressed over the outboard end of the Slotted Stud Plate tightly against the cavity insulation to prevent the insulation from separating from the structural backing/air barrier. The friction fit between the Insulation Support and the Slotted Stud Plate restrains the insulation during construction which is commonly installed in advance of the exterior masonry veneer. Subsequent installation of the V-Tie™ sandwiches the Insulation Support between the insulation and V-Tie™, thereby locking the Insulation Support in place and ensuring a reliable and permanent insulation support system.

The insulation support is a standard component of the system, but it is optional where the insulation is otherwise supported, and not required where no insulation is placed within the air space.

The Slotted Stud Tie (Type II) system is designed to transfer the lateral load from the exterior masonry veneer axially and normal to the structural backing. The connection between the V-Tie™ and Slotted Stud Plate by way of a vertical slot does not resist differential movement between the structural backing and the masonry veneer in the vertical direction, and therefore, does not offer composite action between the structural backing and the masonry veneer. For the design of shear connected masonry veneer/(steel) stud systems (i.e. composite wall construction), see Fero Stud Shear™ Connector product literature.

The fasteners connecting the Slotted Stud Plate (Type II) to the side surfaces of the structural backing member resist loads in shear. This fastener orientation and their inboard position within the wall system provide a more structurally-desirable connection to the structural backing than surface-mounted tie systems which subject the fasteners to direct tension and generally higher moisture loads.

Although four (4) holes are provided to receive fasteners, generally, (a minimum of) two screws per connector are sufficient to resist the imposed masonry veneer loads.

In addition to its use in unit masonry veneer applications, including both clay brick and concrete masonry, the Slotted Stud Tie (Type II) system can be utilized in the application of conventional stone masonry veneer set in mortar.

Unit Masonry, Dimension Cut, and Manufactured Stone Veneer Applications

SLOTTED STUD TIE (TYPE II)

Slotted Stud Tie (Type II) Design Data

Slotted Stud Tie (Type II) Design Data (Canada)

Design Parameter	Design Data ^{(i),(ii)} Side Mounted	
1. Mechanical Free Play: ⁽ⁱⁱⁱ⁾ (with FERO V-Tie™)	0.50 mm (max) (0.02")	
2. Serviceability at 0.45 kN (100 lbs): ⁽ⁱⁱⁱ⁾ Displacement: Displacement + Mechanical Free Play:	0.10 mm (0.004") 0.06 mm (max) (0.024")	
3. Factored Resistance: (ϕP_{ult}) ^{(iv),(v),(vi)}	2.5 kN (560 lbs.)	
4. Maximum Recommended Spacing: ^(vii)	Horizontal: 800 mm (32")	Vertical: 600 mm (24")

- (v) The stated tie factored resistance is based on the capacity of FERO tie components, and does not consider fastener resistance. A compatible fastener having an adequate factored resistance must be selected (by design in accordance with CSA A370-04).
- (vi) The factored resistance of the mortar pull-out or push-through for the V-Tie™ embedded at the centreline of 90 mm (3.5") brick veneer utilizing Type S or N mortar exceeds or equals the tabled factored resistance, ϕP_{ult} . That is, failure by pull-out/push-through of the mortar joint does not govern.
- (vii) Maximum recommended tie spacings are the maximum spacings permitted by CSA S304.1-04, *Design of Masonry Structures*. For a particular design, the actual tie spacings are calculated such that the factored resistance of the tie, ϕP_{ult} , equals or exceeds the effect of factored loads. See S304.1-04 for the design of masonry veneer systems.

Slotted Block Tie (Type II) Design Data (United States)

Design Parameter	Design Data ^{(i),(ii)} Side Mounted	
1. Mechanical Free Play: ⁽ⁱⁱⁱ⁾ (with FERO V-Tie™)	0.02" (max) (0.50 mm)	
2. Serviceability at 100 lbs (0.45 kN): ⁽ⁱⁱⁱ⁾ Displacement: Displacement + Mechanical Free Play:	0.004" (0.10 mm) 0.024" (max) (0.60 mm)	
3. Nominal Strength: ^{(iv),(v),(vi),(vii),(ix)}	750 lb (3.4 kN)	
4. Recommended Design Load: ^{(iv),(v),(vi),(vii),(ix)}	330 lb (1.5 kN)	
5. Maximum Recommended Spacing: ^(vii)	Horizontal: 32" (813 mm)	Vertical: 18" (457 mm)

- (iv) The nominal strength of the Slotted Stud Tie (Type II) system is determined by test and is reported as the average ultimate strength of the tie samples. In accordance with ACI 530/ASCE 5/TMS 402, using Strength Design, a suitable strength-reduction factor must be applied to the nominal strength to determine the tie design strength. Similarly, under Allowable Stress Design, an appropriate safety factor must be applied to determine an allowable load value. The tabled "Recommended Design Load" reflects a safety factor of 2.25 (that is, 75% of 3.0). [See also Note (vi) when assigning a strength-reduction factor to the nominal strength].
- (v) The stated nominal strength and recommended design load do not consider fastener capacity. A compatible fastener (or fasteners) having an adequate strength must be selected (by design in accordance with ACI 530.1/ASCE 6/TMS 602).
- (vi) The nominal strength (and corresponding recommended design load) of the mortar pull-out or push-through for the V-Tie™ embedded at the centerline of 3.5" (90 mm) brick veneer utilizing Type M, S or N mortar exceeds or equals the tabled nominal strength (and recommended design load). That is, failure by pull-out/push-through of the mortar joint does not govern.
- (vii) Maximum recommended tie spacings are the maximum spacings permitted by ACI 530/ASCE 5/TMS 402 using prescriptive requirements for anchored masonry veneer. The prescriptive requirements in ACI 530/ASCE 5/TMS 402 further limit a tie tributary area to not more than 2.67 ft² (0.25 m²) wall area [with reduced areas for high Seismic Design Categories and in areas of high winds] unless the veneer is alternatively designed using a rational, engineered method (termed "Alternative Design of Anchored Masonry Veneer"). Where an Alternative Design is used, the required tie spacing may be calculated such that the design strength of the tie equals or exceeds the required strength. See ACI 530/ASCE 5/TMS 402 for the design of masonry veneer systems.
- (viii) The Slotted Stud Plate (Type II) with V-Tie™ satisfies ACI 530/ASCE 5/TMS 402 requirements for minimum wire size of W1.7 (MW11) and for ends bent to form a minimum 2 in (50.8 mm) extension.
- (ix) ACI 530/ASCE 5/TMS 402 requires joint reinforcement in masonry veneer in high Seismic Design Categories to be mechanically attached to the masonry tie.

Design Philosophy: Robert G. Drysdale, Ph. D., P.Eng., President of Drysdale Engineering and Associates Limited, examined masonry tie usage in a brief report entitled "Structural Requirements for Non-Loadbearing Masonry Backup Walls and Potential for Composite Action", dated September 4, 1991. In his report, Drysdale comments, "...theoretically (composite action) is a very attractive engineering idea." He further states that "... literature, calculations, and tests used to develop design information for such systems must clearly show not only the benefits of the coupling of the two wythes, but also the detrimental effects of restrained differential movements."* Drysdale concludes by noting, "At this point in time, practice and 'conventional' wisdom has been to allow the two wythes to move independently in the plane of the wall, and ties have specifically been designed to accommodate such movements."

The design of the Slotted Stud Tie (Type II) not only satisfies this "conventional" wisdom, but also has been engineered to eliminate many issues problematic for the multi-component tie. It offers positive restraint between tie components to prevent disengagement, reduced mechanical free play, limited deformation under load, and "side mounting", which places the fastener in shear rather than direct tension and minimizes the moisture load to which the fasteners are subjected.

*The effects of restrained differential movement associated with Shear Connected Walls has been addressed in Prairie Masonry Research Institute technical booklet entitled "Differential Movement In Cavity Walls and Veneer Walls Due To Material and Environmental Effects"; authored by Ajay Goyal, Dr. Michael A. Hatzinikolas and Prof. Joseph Warwaruk, dated August 1992. Although the effects of restrained differential movements are real, their magnitudes were found to be relatively small and readily could be accommodated by composite wall design.

Design data for the Slotted Stud Tie (Type II) system are reported separately for Canada and the United States in the following tables because design methods and requirements for masonry ties and their uses differ between their respective codes and standards.

Notes:

- (i) These design data are based on connector testing in accordance with CSA A370-04, *Connectors for Masonry*, with no surcharge and with test samples having the following configuration: 127 mm [5"] cavity; Slotted Stud Plate (Type II) having (IG) of 102 mm [4"]; 25 mm [1"] air space; two (2) fasteners connecting Stud Plate and steel stud; standard FERO V-Tie™; and V-Tie™ engaged into Stud Plate at centreline of vertical adjustment. Smaller cavity widths and/or the addition of insulations providing lateral support to the Stud Plate will increase the tabled factored resistance of the tie and reduce tie deflection.
- (ii) These design data reflect both the windward (compression) and leeward (tension) capacities of the Slotted Stud Tie (Type II) system, with the governing values listed.
- (iii) The Slotted Stud Tie (Type II) system satisfies the limiting requirements for serviceability (tie displacement and mechanical free play) in CSA A370-04. Tabled mechanical free play is for stainless steel components. The mechanical free play for hot-dip galvanized components is less.
- (iv) The ultimate strength of the Slotted Stud Tie (Type II) system, P_{ult} , is determined in accordance with CSA A370-04 and is calculated by multiplying the average tie strength established by testing by (1 – 1.64 cov). The factored resistance of the tie system (ϕP_{ult}) is calculated using the Limit States Design procedures of CSA A370-04.

Notes:

- (i) These design data are based on connector testing in accordance with CSA A370-04, *Connectors for Masonry*, with no surcharge and with test samples having the following configuration: 127 mm [5"] cavity; Slotted Stud Plate (Type II) having (IG) of 102 mm [4"]; 25 mm [1"] air space; two (2) fasteners connecting Stud Plate and steel stud; standard FERO V-Tie™; and V-Tie™ engaged into Stud Plate at centerline of vertical adjustment. The test method for ties in CSA A370-04 is comparable to that of ASTM E754, *Test Method for Pullout Resistance of Ties and Anchors Embedded in Masonry Mortar Joints*, and provides similar and more conservative results. Smaller cavity widths and/or the addition of insulations providing lateral support to the Stud Plate will increase the tabled factored resistance of the tie and reduce tie deflection. Prescriptive requirements for anchored masonry veneer under ACI 530/ASCE 5/TMS 402 limit the cavity to a maximum width of 4-1/2" (114 mm) unless the veneer is alternatively designed using a rational, engineered design method (termed "Alternative Design of Anchored Masonry Veneer").
- (ii) These design data reflect both the windward (compression) and leeward (tension) capacities of the Slotted Stud Tie (Type II) system, with the governing values listed.
- (iii) The Slotted Stud Plate (Type II) with V-Tie™ satisfies the 1/16" (1.6 mm) maximum permissible clearance between connecting parts required by ACI 530/ASCE 5/TMS 402. Tabled mechanical free play is for stainless steel components. The mechanical free play for hot-dip galvanized components is less.