

SLOTTED BLOCK TIE (TYPE II)

SLOTTED BLOCK TIE (TYPE II) APPLICATION

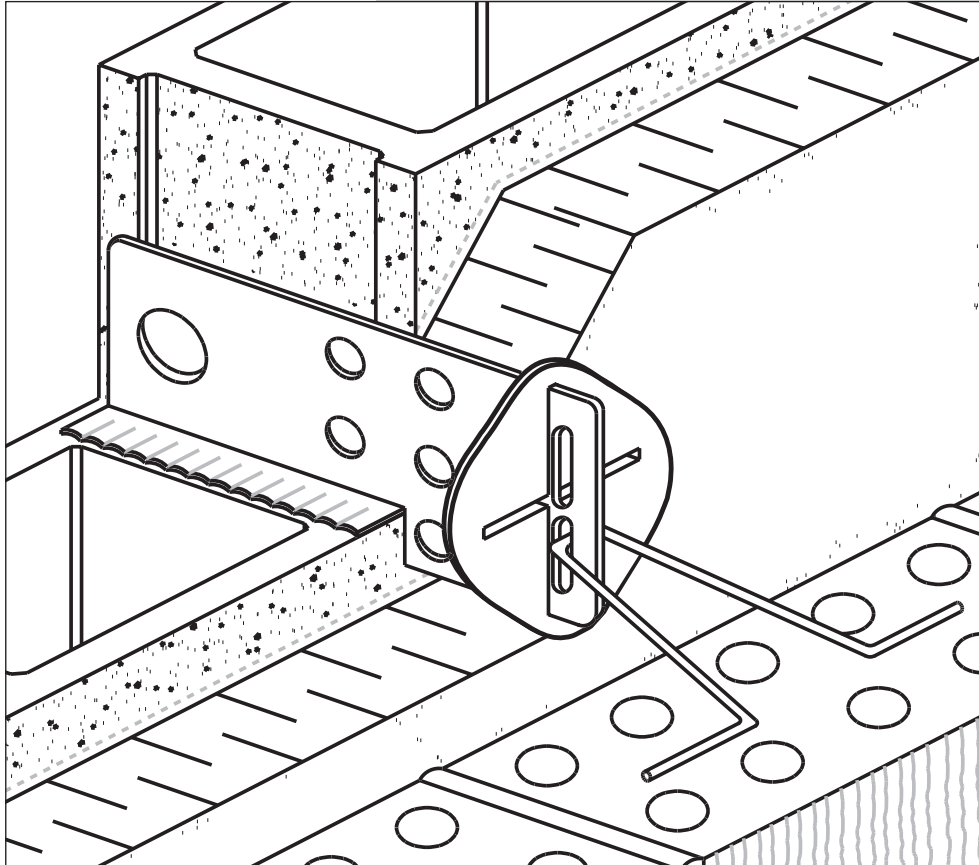

Introduction

The Slotted Block Tie (Type II) was developed for masonry cavity wall construction where significant differential movement between the veneer and the backup block wythe is expected, such as high walls or multi-storey buildings with full height veneer. The Slotted Block Tie (Type II) allows for up to 60 mm (2.4") of construction adjustability and up to 25 mm (1") differential movement between the veneer and the backup wythe.

Note that as the Slotted Block Tie (Type II) is only capable of transferring forces perpendicular to the wall and not parallel to the wall, composite action cannot be achieved between the masonry wythes. For the design of *ShearTruss* masonry cavity wall systems (i.e. composite masonry cavity walls), see *Fero Block Shear™ Connector* product literature.

Description

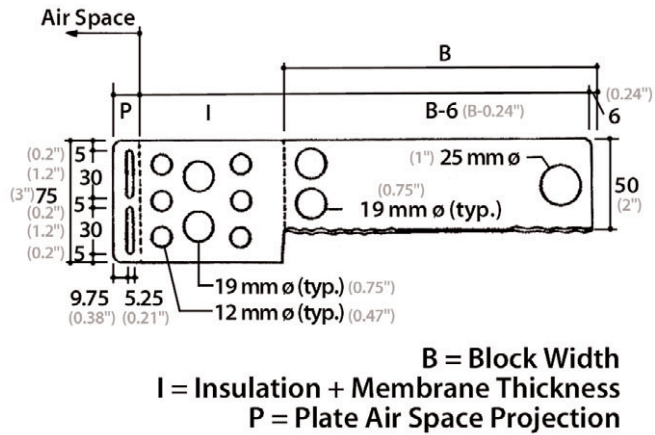

Figure 1 Slotted Block Plate (Type II)

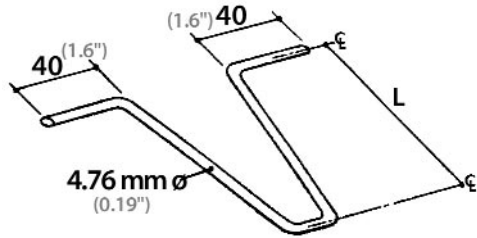

Figure 2 V-Tie™

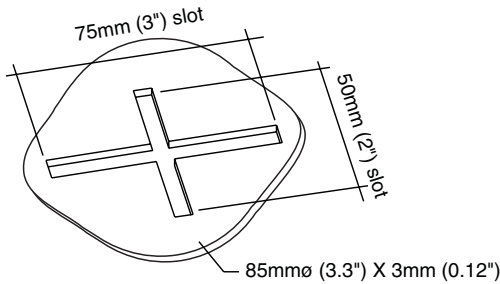

Figure 3 Insulation Support

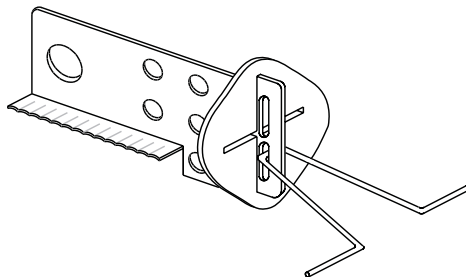

Figure 4 Slotted Block Tie (Type II)

The Slotted Block Tie (Type II) assembly consists of a Slotted Block Plate (Type II), a V-Tie™, and an optional Insulation Support.

Slotted Block Plate (Type II). The Slotted Block Plate (Type II) component as shown in *Figure 1*, is manufactured from 16 gauge (1.61 mm [0.063"] thick) sheet metal conforming to ASTM Standard A570, and is available in hot dipped galvanized finish (conforming to CSA CAN-A370-04 and ASTM A153 requirement of 458g/m²/side [1.5 oz/ft²/side] of zinc coating) and stainless steel.

The length of the Slotted Block Plate (Type II) can vary to accommodate block width, insulation plus membrane thickness (I) of 0 mm (0") and up, and air space width (A) of 25 mm (1") and greater.

Two 30 mm (1.2") high by 5.25 mm (0.23") wide slots at the end of the Slotted Block Plate (Type II) allow for up to 60 mm (2.4") of construction adjustability and up to 25 mm (1") differential movement between the plate and the V-Tie™.

Shear keys and corrugated sections provide for adequate fixity within the concrete block wythe. The notch in the plate assures proper positioning within the concrete block backup wythe.

Thermal bridging reducing holes are incorporated within the insulation thickness portion of the Slotted Block Plate (Type II).

V-Tie.™ The V-Tie™, as shown in *Figure 2*, is manufactured from 4.76 mm (0.19") diameter wire conforming to CSA Standard G30.3, and is available in hot dipped galvanized (conforming to CSA CAN3-A370-04 and ASTM A153 requirement of 458 g/m²/side [1.5 oz/ft²/side] of zinc coating) and stainless steel.

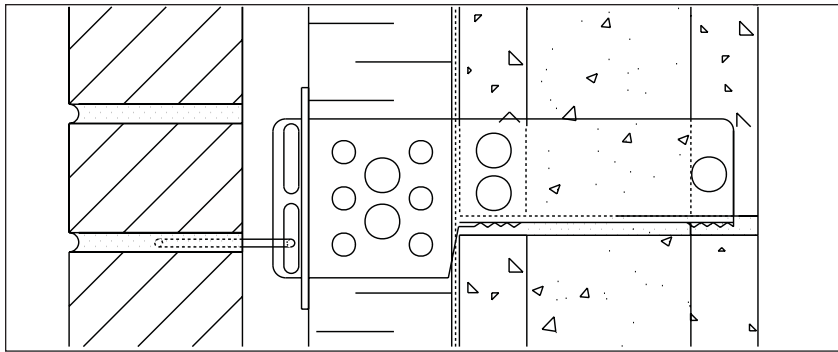

Figure 5 An installation wall section

The legs of the V-Tie™ are mortared into place at the centerline of the brick veneer. V-Tie™ sizes of 60 (2.4"), 80 (3.1"), 100 (3.9"), 120 (4.7"), 140 (5.5"), 160 (6.3"), 180 (7.1"), 200 (7.9"), 225 (8.9") and 250 mm (9.8") lengths are available.

Insulation Support. The Insulation Support is manufactured from polyethylene and is optionally used to secure the sheet insulation in place.

Recommended Design Load and Deflections

1. Free Play (maximum):	0.50 mm (0.02")	
2. 0.45 kN (100 lbs) Deflection		
- free play not included:	0.10 mm (0.004")	
- including free play:	0.60 mm (max) (0.024")	
3. Recommended Design Load:	1.27 kN (284 lbs)	
4. Recommended Design Load Deflection		
- free play not included:	0.28 mm (0.011")	
5. Maximum Recommended Spacing:	Horizontal:	Vertical:
	800 mm (32")	600 mm (24")

Notes

- i) The design values reflect both the windward and leeward capacity of the Slotted Block Tie (Type II) system, with the governing values listed.
- ii) The tie system recommended design load value was formulated using working stress design following the procedures of CSA CAN3-A370-04 "Connectors for Masonry", ACI/ASCE/TMS/518 and U.B.C. The value has been reduced to account for test result variation, and reflects a factor of safety of 2.25 (i.e. 75% of 3.0), as per Table 3 (A370).
- iii) The allowable mortar pullout design load for the V-Tie™ embedded at the centerline of 90 mm (3.5") brick veneer utilizing Type M, S or N mortar, exceeds or equals the recommended design load listed above.
- iv) The allowable mortar pull-out or push-out design load for the Slotted Block Plate (Type II) embedded in the mortar joint of 90 (4"), 140 (6"), 190 (8"), 240 (10") and 290 mm (12") concrete block work utilizing Type S mortar, exceeds or equals the recommended design load listed above.
- v) The above design values are based on test results utilizing a 127 mm (5") cavity (25 mm [1"] air space). No insulation was used. Note that for smaller cavity widths and/or with the addition of insulation sheathing providing lateral tie support, increased tie system design loads and reduced tie system deflections may be realized.
- vi) Maximum recommended spacing reflects maximum allowable by CSA-A370-04, ACI/ASCE/TMS/518 and U.B.C. Design will ultimately govern spacing.

SLOTTED BLOCK TIE (TYPE II)

Specification Guidelines

The Slotted Block Plate (Type II) specification length (B) refers to the standard embedment length into the block, the specification length (I) refers to the actual thickness of the insulation plus membrane, while the specification length (P) refers to the length of projection of the plate into the air space.

The V-Tie™ specification length (L) should be selected to provide for placement of the legs of the V-Tie™ at the centerline of brick veneer.

The 80 mm (3.1") V-Tie™ is utilized in the Slotted Block Tie (Type II) system consisting of 25 mm (1") air space and 90 mm (3.5") brick veneer.

The Insulation Support is standard.

Design Philosophy

Robert G. Drysdale, Ph. D., P.Eng., President of Drysdale Engineering and Associates Limited examined masonry tie usage in a brief report entitled "Structural Requirements for Non-Loadbearing Masonry Backup Walls and Potential for Composite Action" and dated September 4, 1991. In the report Drysdale stated " . . . theoretically (composite action) is a very attractive engineering idea." Drysdale further stated that " . . . Literature, calculations, and tests used to develop design information for such systems must clearly show not only the benefits of the coupling of the two wythes, but also the detrimental effects of restrained differential movements."* Drysdale concluded by noting "At this point in time practice and 'conventional' wisdom has been to allow the two wythes to move independently in the plane of the wall and ties have specifically been designed to accommodate such movements."

The design of the Slotted Block Tie (Type II) not only satisfies this "conventional" wisdom, but eliminates numerous traditional masonry tie potential pitfalls such as welded connections, fasteners into concrete blockwork, multi-part ties that do not possess positive restraint between tie components, multi-part ties that allow excessive free play, and multipart ties that undergo excessive deformation under load. Above all this, the Slotted Block Tie (Type II) has been engineered.

** The effects of restrained differential movement associated with Shear Connected walls has been addressed in Prairie Masonry Research Institute technical booklet entitled "Differential Movement In Cavity Walls And Veneer Walls Due To Material and Environmental Effects", authored by Ajay Goyal, Dr. Michael A. Hatzinikolas and Prof. Joseph Warwaruk and dated August 1992. Although the effects of restrained differential movements are real, their magnitudes were found to be relatively small and could easily be incorporated into composite wall designs, and could easily be incorporated into composite wall designs.*



Fero Corporation