

LATERAL TIE-CLIP

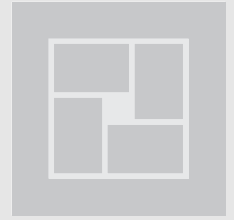

Introduction

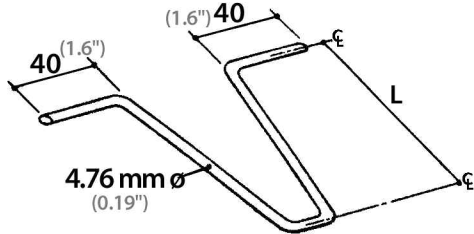

Figure 1 V-Tie™

The unique configuration of the V-Tie™ (see Figure 1) intended for use with FERO Engineered Masonry Connectors and the Lateral Tie-Clip offers greater pullout and pushthrough capacity from the masonry mortar bed than do other proprietary and conventional ties. The area of mortar effective in resisting tie pullout for the V-Tie™ and for alternative ties embedded in a masonry veneer is illustrated in Figure 2. A comparison of the pullout capacities of these various tie types is presented in Table 1.

For masonry veneer under high seismic loading, the Building Code in some jurisdictions requires mechanical attachment of continuous single wire joint reinforcement to the masonry tie. Whether required prescriptively, or otherwise desired, this design requirement can be satisfied using the Lateral Tie-Clip with the V-Tie™, as shown in Figure 3.

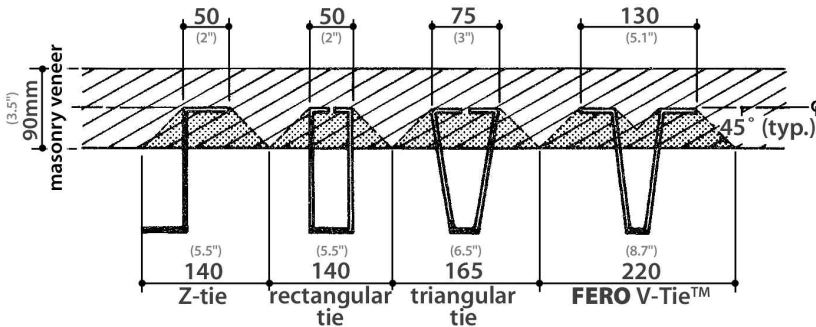

Figure 2 Effective Mortar Bed Area Resisting Tie Pullout

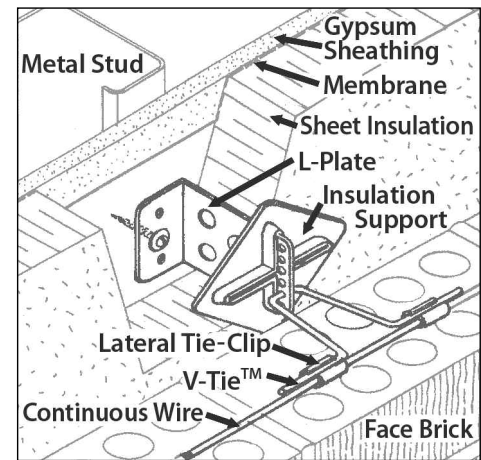

Figure 3 Lateral Tie-Clip Application

Lateral Tie-Clip System

The shape and dimensions of the Lateral Tie-Clip are shown in Figure 4. A Tie-Clip is installed by inserting the continuous wire through the slot on the upper surface of the Tie-Clip, and then sliding the Tie-Clip onto a leg of the V-Tie™.

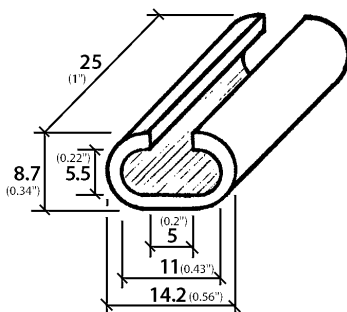

Figure 4 Lateral Tie-Clip

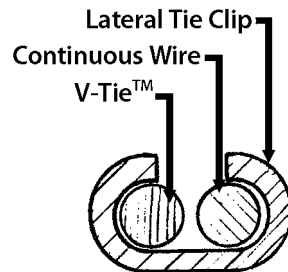

Figure 5 Lateral Tie-Clip Placement

With the Lateral Tie-Clip in place, the continuous joint wire and the wire leg of the V-Tie™ are mechanically connected (see Figure 5). Free play between the adjacent wires within the Tie-Clip is eliminated with the placement of mortar in the bed joint when the next brick course is laid. Two Lateral Tie-Clips, one on each leg of the V-Tie™, are required to appropriately connect the continuous wire reinforcement to each V-Tie™ (see Figure 3). The "Lateral Tie-Clip System" includes both the Lateral Tie-Clip and the V-Tie™. The V-Tie™ is used with nearly all FERO ties, and is described within each of the various tie product literatures.



Fero Corporation

15305 - 117 Avenue, Edmonton, Alberta T5M 3X4

Phone: (780) 455-5098 Fax: (780) 452-5969

www.ferocorp.com info@ferocorp.com

V-Tie™ Pullout Performance

Table 1
Comparison of
Relative Tie Pull-
Out Capacity in
90 mm Masonry
Veneer

Tie Type	Effective Mortar Area mm ² (in ²)	% of V-Tie™ Pull-Out Capacity
FERO V-Tie™	7250 (11.24)	100
Z-Tie	4275 (6.63)	59
Rectangular Tie	4275 (6.63)	59
Triangular Tie	5400 (8.37)	74

Lateral Tie-Clip Description

The Lateral Tie-Clip is manufactured from 16 gauge sheet steel [(1.367 mm) (0.0538") minimum base steel thickness]. The slot in the Lateral Tie-Clip is 5.0 mm (0.2") wide to allow the insertion of 4.76 mm (3/16") diameter continuous wire during installation. The Lateral Tie-Clip is available in both hot-dip galvanized finish and stainless steel. The weight of the hot-dip galvanized finish is not less than 460 g/m²/side (1.5 oz/ft²/side), and satisfies the requirements of CSA A370 (which references ASTM A 123), ACI 530.1/ASCE 6/TMS 602 (which references ASTM A 153, Class B), and the International Codes (which reference ASTM A 153, Class B).

Lateral Tie-Clip System Design Data

The "Lateral Tie-Clip System" includes both the Lateral Tie-Clip and the V-Tie™. Design data for the System are reported separately for Canada and the United States in the following tables because design methods and requirements for masonry ties and their uses differ between their respective codes and standards.

Lateral Tie-Clip System Design Data (Canada)

DESIGN PARAMETER:	DESIGN DATA:	NOTES:
1. Mechanical Free Play (maximum) (between Tie-Clip and V-Tie™):	0.00 mm (0")	(i) The tabled strength and displacement are based on tests using the FERO V-Tie™ with two Lateral Tie-Clips (one per V-Tie™ leg). No mortar was used. With the addition of mortar providing confinement, increased factored resistance and reduced tie system displacement may be realized. (ii) The ultimate strength of the Lateral Tie-Clip System, P_{ult} , is determined in accordance with CSA A370-04, "Connectors for Masonry," and is calculated by multiplying the average strength established by testing by (1 - 1.64 cov). The factored resistance of the Lateral Tie-Clip System (ΦP_{ult}) is calculated using Limit States Design with $\Phi = 0.9$, and following the procedures of CSA A370-04.
2. Serviceability at 0.45 kN (100 lbs) Displacement:	1.01 mm (0.04")	
Displacement + Mechanical Free Play:	1.01 mm (0.04")	
3. Factored Resistance (ΦP_{ult}):	0.73 kN (164 lbs)	
4. Configuration:	Minimum 2 Tie-Clips per V-Tie™ (1 per leg)	

Lateral Tie-Clip System Design Data (U.S.)

DESIGN PARAMETER:	DESIGN DATA:	NOTES:
1. Mechanical Free Play (maximum) (between Tie-Clip and V-Tie™):	0.00 mm (0")	(i) The tabled strength and displacement are based on tests using the FERO V-Tie™ with two Lateral Tie-Clips (one per V-Tie™ leg). No mortar was used. With the addition of mortar providing confinement, increased nominal strength/design load and reduced tie system displacement may be realized. (ii) The nominal strength of the Lateral Tie-Clip system is determined by test and is reported as the average ultimate strength of the tested tie samples. In accordance with ACI 530.1/ASCE 6/TMS 602, using Strength Design, a suitable strength-reduction factor must be applied to the nominal strength to determine the tie design strength. Similarly, under Allowable Stress Design, an appropriate safety factor must be applied to determine an allowable load value. The tabled "Recommended Design Load" reflects a safety factor of 2.25 (that is, 75% of 3.0).
2. Serviceability at 0.45 kN (100 lbs) Displacement:	1.01 mm (0.04")	
Displacement + Mechanical Free Play:	1.01 mm (0.04")	
3. Nominal Strength:	1.93 kN (434 lbs)	
4. Recommended Design Load:	0.86 kN (193 lbs)	
5. Maximum Recommended Spacing:	Minimum 2 Tie-Clips per V-Tie™ (1 per leg)	