

# ICF - MASONRY VENEER TIE

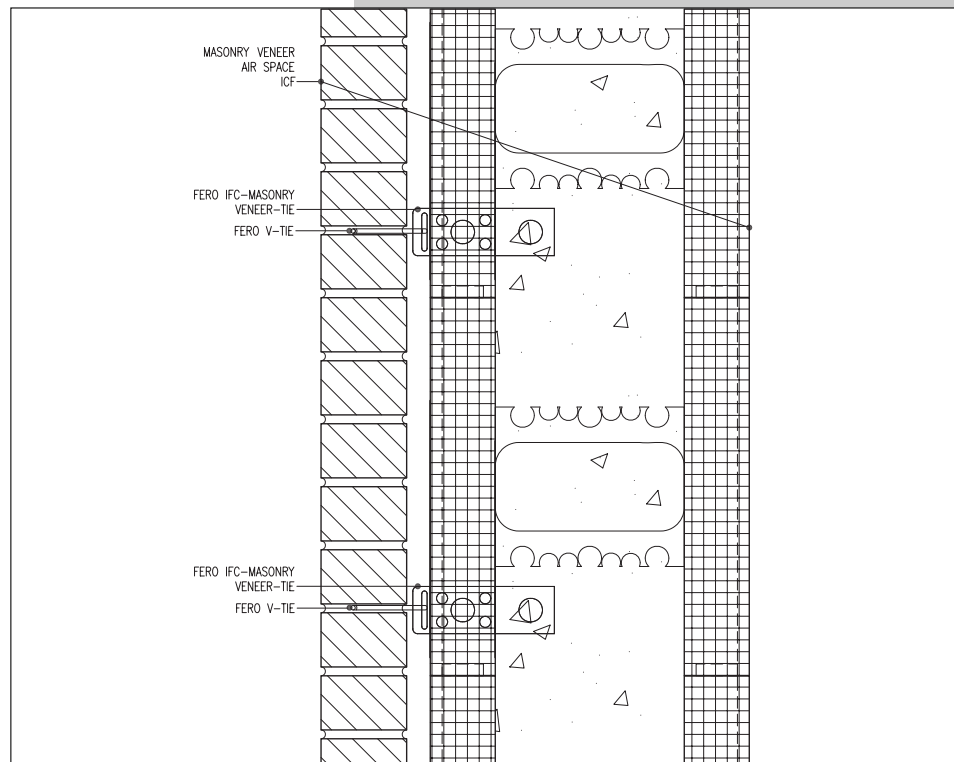
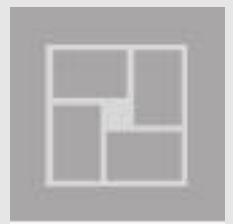

**VERTICAL  
SECTION  
SHOWING THE  
ICF-MASONRY  
VENEER TIE**

## Introduction

The ICF-Masonry Veneer Tie system consists of a Plate (a vertically oriented, flat plate), a V-Tie™ (a V-shaped wire), and a reusable tie Spacer. These individual components are shown in Figures 1, 2, and 4, respectively. The installed ICF-Masonry Veneer Tie system is shown in vertical elevation on the cover illustration, and on plan section in Figure 3. The ICF-Masonry Veneer Tie system is specifically designed to facilitate placement of masonry veneer over ICF (Insulated Concrete Form) construction using an adjustable multi-component tie system.

Tensile and compressive lateral loads applied to the masonry veneer are transferred through the V-Tie™ to the vertically-oriented Plate, which transfers these loads axially to the concrete structural backing by direct embedment of its inboard end into the concrete core of the ICF. The vertical slot in the exterior end of the Plate through which the wire V-Tie™ is inserted provides a positive connection without the possibility of V-Tie™ disengagement during construction and in-service (in compliance with requirements in CSA A370, "Connectors for Masonry", and ACI 530/ASCE 5/TMS 402, "Building Code Requirements for Masonry Structures"). The slot permits up to 64 mm (2.5") of in-situ vertical adjustment, which ensures that a masonry veneer bed joint will always be coincident with the V-Tie™. The slot also accommodates vertical differential movement between the masonry veneer and the ICF structural backing. The ICF-Masonry Veneer Tie system is an "embedded" tie system, this being a positive connector that does not rely on mechanical fasteners in tension or shear to transfer structural loads from the veneer to the structural backing.

## Introduction...cont.

The ICF-Masonry Veneer system can accommodate a range of insulation thicknesses from 0 to 102 mm (0 to 4"), and air space widths of 25 mm (1") and greater. The Plate is easily inserted through a clean cut in the ICF foam insulation panel. It has sufficient length to embed in the ICF concrete core not less than 50 mm, to traverse the thickness of the ICF board insulation, and to extend 18 mm (0.7") into the air space in order to expose its leading edge and facilitate in-situ placement of the V-Tie™. The V-Tie™ is inserted through the vertical slot along the leading edge of the Plate coincident with the mortar bed joint so as to extend horizontally and normally to the structural backing without reducing tie capacity. The legs of the V-Tie™ are positioned along the centreline of the veneer within the placement tolerances permitted by the building code having jurisdiction. Adjustment normal to the wall is facilitated by selecting an appropriate length of V-Tie™.

## Components and Specifications

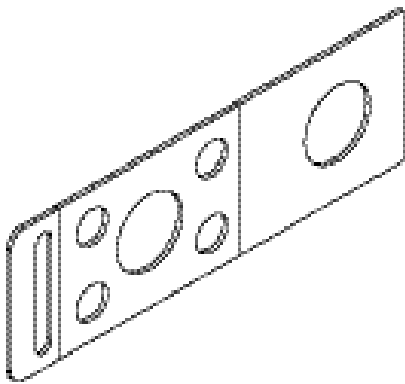

Figure 1 Plate

**Plate:** The Plate is manufactured from 16 gauge sheet steel (1.367 mm [0.0538"] minimum base steel thickness) and is available in both hot-dip galvanized finish and stainless steel. The weight of hot-dip galvanized finish is not less than 460 g/m<sup>2</sup>/side (1.5 oz/ft.<sup>2</sup>/side), and satisfies the requirements of CSA A370 (which references ASTM A123), ACI 530.1/ASCE 6/TMS 602, Specification for Masonry Structures (which references ASTM A153, Class B) and the International Codes (which reference ASTM A153, Class B). The incorporation of holes through the mid-body of the Plate minimizes thermal conductivity through the tie system, and a single 25 mm  $\Phi$  hole through its inboard end ensures mechanical engagement with the poured concrete core of the ICF.

On its outboard end, the length of the Plate is 18 mm (0.7") longer than the specification length (L). The specification length is the total distance between the exterior face of the board insulation and the exterior face of the structural backing into which the Plate is embedded (for ICF construction, without additional insulating materials included, the specification length is the foam board insulation thickness). The Plate is available in specification lengths (L) of 0 (0"), 28 (1.1"), 41 (1.6"), 54 (2.1"), 67 (2.6"), 79 (3.1"), 92 (3.6") and 105 (4.1") mm. Intermediate sizes are also available. The overall length of Plate will also include for an embedment of not less than 50 mm into the concrete core of the ICF.

**V-Tie™:** The V-Tie™ is manufactured from 4.76 mm (0.19") diameter wire and is available in both hot-dip galvanized finish and stainless steel. The weight of the hot-dip galvanized finish is not less than 460 g/m<sup>2</sup> (1.5 oz/ft.<sup>2</sup>) and satisfies the requirements of CSA A370 (which references ASTM A123), ACI 530.1/ASCE 6/TMS 602 (which references ASTM A153, 458 g/m<sup>2</sup>) and the International Codes (which reference ASTM A153, Class B, 458 g/m<sup>2</sup>).

The V-Tie™ is available in a variety of standard lengths to accommodate different thicknesses of masonry veneer and design widths of air space. The design length of V-Tie™ should be selected so its legs are positioned along the centreline of the masonry veneer. Varying lengths of V-Tie™ can be appropriately selected by the mason on the jobsite to facilitate in-situ adjustment normal to the structural backing (where needed to accommodate construction tolerances). Standard lengths include 60 (2.4"), 80 (3.1"), 100 (3.9"), 120 (4.7"), 140 (5.5"), 160 (6.3"), 180 (7.1"), 200 (7.9"), 225 (8.9") and 250 mm (9.8"). By selecting the appropriate length of wire V-Tie™, cavity widths of 15 mm (0.59") to 200 mm (8") can be accommodated. Specify the V-Tie™ size as the distance from the exterior face of the ICF insulation to the centreline of the masonry veneer.

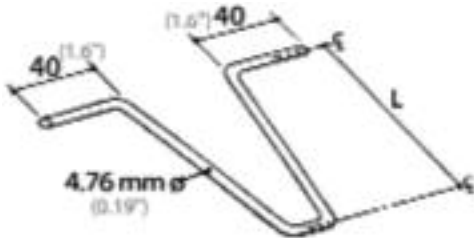

Figure 2 V-Tie™

## Structural Composite Action

**Tie Spacer:** The tie Spacer is a rigid plastic blocking. On site, it is hand-pressed into the vertical slot on the outboard end of the Plate. The inboard face of the Spacer bears against the exterior face of the ICF board insulation to ensure that the Plate is correctly positioned, and that the required depth of Plate engages the ICF unit. The reusable Spacer is subsequently removed from the Plate after the concrete has set, and before insertion of the V-Tie™ into the Plate.

The ICF-Masonry Veneer system is designed to transfer incident lateral load from the exterior masonry veneer axially and normal to the structural backing. The connection between the V-Tie™ and the slotted Plate does not resist differential movement in the vertical direction between the structural backing and the masonry veneer, and therefore does not offer composite action.

For the design of shear connected masonry veneer systems, the Plate is fabricated with a series of holes along its leading edge through which the V-Tie™ is inserted. This engagement between V-Tie™ and Plate restricts vertical displacements and provides composite action between the veneer and structural backing. For additional information about shear connection and composite action, see Fero Shear Connector product literature.

Figure 3 - Plan showing the V-Tie and Veneer

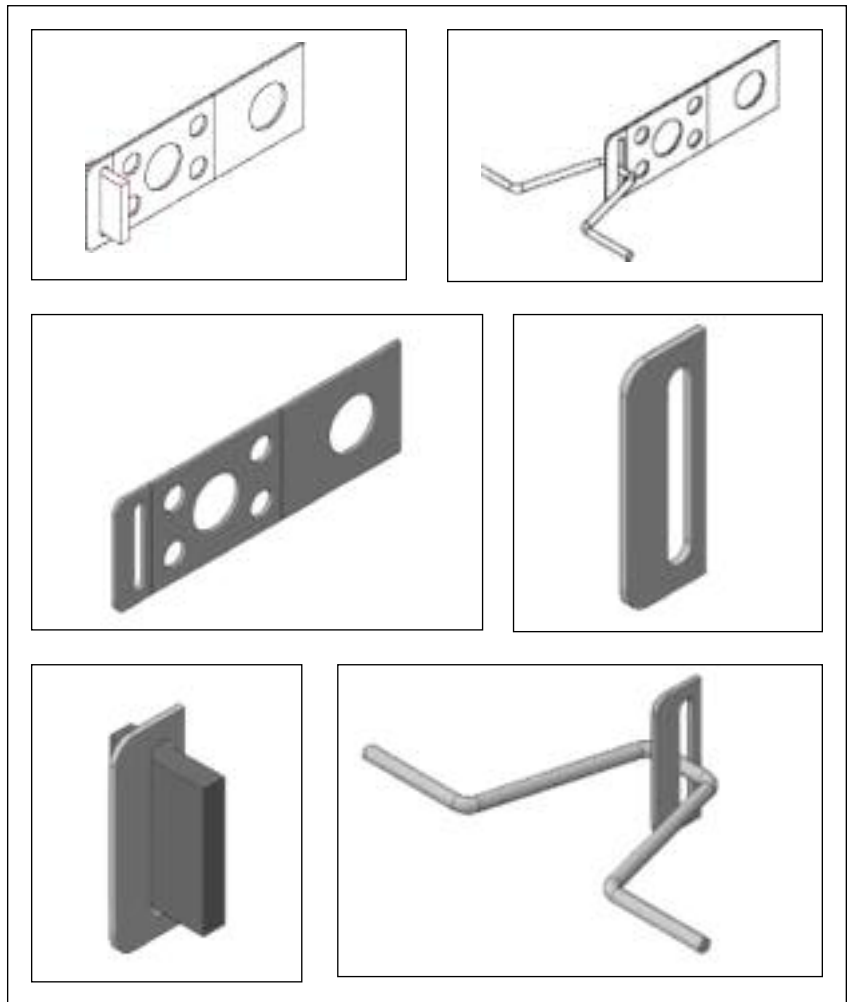
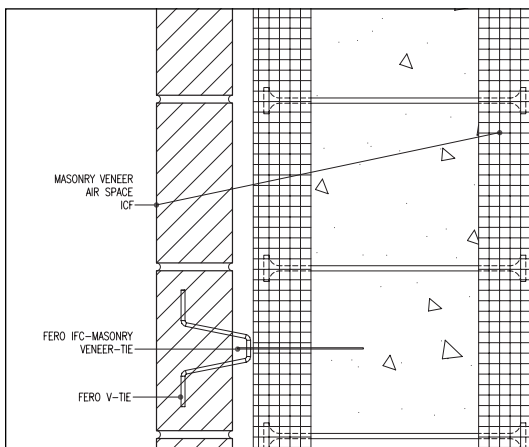

Figure 4 - Components and Installation Sequence

# ICF - MASONRY VENEER TIE

# ICF-Masonry Veneer System Design Data

In the following tables, design data for the ICF-Masonry Veneer system are reported separately for Canada and the United States because design methods and requirements for masonry ties and their uses differ between their respective codes and standards.

## ICF - Masonry Veneer Tie System Design Data (Canada)

Design Parameter	Design Data Tie is Cast in Concrete on Inboard End <sup>(i),(iii)</sup>
1. Mechanical Free Play: <sup>(iii)</sup> (with FERO V-Tie™)	0.80 mm (max) (0.031")
2. Serviceability at 0.45 kN (100 lbs) <sup>(iii)</sup> Deflection Deflection + Mechanical Free Play	0.47 mm (0.019") 1.27 mm (max) (0.05")
3. Factored Resistance ( $\phi P_{ut}$ ) <sup>(iv),(v)</sup>	1.51 kN [331 lbs.]
4. Maximum Recommended Spacing: <sup>(vi)</sup>	Horizontal: 800 mm [32"] Vertical: 600 mm [24"]

- (v) The factored resistance of the mortar pull-out or push-through for the V-Tie™ embedded at the centreline of 90 mm (3.5") brick veneer utilizing Type S or N mortar exceeds or equals the tabled factored resistance,  $\phi P_{ut}$ . Failure by pull-out/push-through of the mortar joint does not govern.
- (vi) Maximum recommended tie spacings are the maximum spacings permitted by CSA S304.1-04, Design of Masonry Structures. For a particular design, the actual tie spacings are calculated such that the factored resistance of the tie,  $\phi P_{ut}$ , equals or exceeds the effect of factored loads. See S304.1-04 for the design of masonry veneer systems.

### Notes:

- (i) These design data are based on connector testing in accordance with CSA A370-04, Connectors for Masonry, with no surcharge and with test samples having the following configuration: 127 mm [5"] cavity; 102 mm [4"] Plate; 25 mm [1"] air space; standard FERO V-Tie™; and V-Tie™ engaged into the Plate at centreline of vertical adjustment. Smaller cavity widths and/or the addition of insulations providing lateral support to the tie Plate will increase the tabled factored resistance of the tie and reduce tie deflection.
- (ii) These design data reflect both the windward (compression) and leeward (tension) capacities of the ICF-Masonry Veneer Tie system, with the governing values listed.
- (iii) The ICF-Masonry Veneer Tie system satisfies the limiting requirements for serviceability (tie displacement and mechanical free play) in CSA A370-04. Tabled mechanical free play is for stainless steel components. The mechanical free play for hot-dip galvanized components is less.
- (iv) The ultimate strength of the ICF-Masonry Veneer Tie system,  $P_{ut}$ , is determined in accordance with CSA A370-04 and is calculated by multiplying the average tie strength established by testing by (1 - 1.64 cov). The factored resistance of the tie system ( $\phi P_{ut}$ ) is calculated using the Limit States Design procedures of CSA A370-04.

## ICF - Masonry Veneer Tie System Design Data (U.S.)

Design Parameter	Design Data Tie is Cast in Concrete on Inboard End <sup>(i),(iii)</sup>
1. Mechanical Free Play: <sup>(iii)</sup> (with FERO V-Tie™)	0.031" (max) 0.80 mm
2. Serviceability at 100 lbs (0.45 kN) <sup>(iii)</sup> Deflection Deflection + Mechanical Free Play	(0.019") 0.47 mm (0.05") (max) 1.27 mm
3. Nominal Strength <sup>(iv),(v),(vii),(viii)</sup>	452 lb [2.01 kN]
4. Recommended Design Load <sup>(iv),(v),(vii),(viii)</sup>	200 lb [0.89 kN]
5. Maximum Recommended Spacing: <sup>(vi)</sup>	Horizontal: [32"] 813 mm Vertical: [18"] 457 mm

- (iv) The nominal strength of the ICF-Masonry Veneer Tie system is determined by test and is reported as the average ultimate strength of the tie samples. In accordance with ACI 530/ASCE 5/TMS 402, using Strength Design, a suitable strength-reduction factor must be applied to the nominal strength to determine the tie design strength. Similarly, under Allowable Stress Design, an appropriate safety factor must be applied to determine an allowable load value. The tabled "Recommended Design Load" reflects a safety factor of 2.25 (that is, 75% of 3.0). [See also Note (v) when assigning a strength-reduction factor to the nominal strength].
- (v) The nominal strength (and corresponding recommended design load) of the mortar pull-out or push-through for the V-Tie™ embedded at the centerline of 3.5" (90 mm) brick veneer utilizing Type M, S or N mortar exceeds or equals the tabled nominal strength (and recommended design load). That is, failure by pull-out/push-through of the mortar joint does not govern.
- (vi) Maximum recommended tie spacings are the maximum spacings permitted by ACI 530/ASCE 5/TMS 402 using prescriptive requirements for anchored masonry veneer. The prescriptive requirements in ACI 530/ASCE 5/TMS 402 further limit a tie tributary area to not more than 2.67 ft.<sup>2</sup> (0.25 m<sup>2</sup>) wall area [with reduced areas for high Seismic Design Categories and in areas of high winds] unless the veneer is alternatively designed using a rational, engineered method (termed "Alternative Design of Anchored Masonry Veneer"). Where an Alternative Design is used, the required tie spacing may be calculated such that the design strength of the tie equals or exceeds the required strength. See ACI 530/ASCE 5/TMS 402 for the design of masonry veneer systems.
- (vii) The ICF-Masonry Veneer Tie system satisfies ACI 530/ASCE 5/TMS 402 requirements for minimum wire size of W1.7 (MW11) and for ends bent to form a minimum 2 in (50.8 mm) extension.
- (viii) ACI 530/ASCE 5/TMS 402 requires joint reinforcement in masonry veneer in high Seismic Design Categories to be mechanically attached to the masonry tie.

### Notes:

- (i) These design data are based on connector testing in accordance with CSA A370-04, Connectors for Masonry, with no surcharge and with test samples having the following configuration: 5" [127 mm] cavity; 4" [102 mm] Plate; 1" [25 mm] air space; standard FERO V-Tie™; and V-Tie™ engaged into the Plate at centerline of vertical adjustment. The CSA A370-04 tie test method is comparable to that of ASTM E754, Test Method for Pullout Resistance of Ties and Anchors Embedded in Masonry Mortar Joints, and provides similar and more conservative results. Smaller cavity widths and/or the addition of insulations providing lateral support to the tie Plate will increase the nominal strength of the tie and reduce tie deflection. Prescriptive requirements for anchored masonry veneer under ACI 530/ASCE 5/TMS 402 limit the cavity to a maximum width of 4-1/2" (114 mm) unless the veneer is alternatively designed using a rational, engineered design method (termed "Alternative Design of Anchored Masonry Veneer").
- (ii) These design data reflect both the windward (compression) and leeward (tension) capacities of the ICF-Masonry Veneer Tie system, with the governing values listed.
- (iii) The ICF-Masonry Veneer Tie system satisfies the 1/16" (1.6 mm) maximum permissible clearance between connecting parts required by ACI 530/ASCE 5/TMS 402. Tabled mechanical free play is for stainless steel components. The mechanical free play for hot-dip galvanized components is less.

Fero Corporation

15305 - 117 Avenue, Edmonton, Alberta T5M 3X4

Phone: (780) 455-5098 Fax: (780) 452-5969

www.ferocorp.com info@ferocorp.com

Patent Pending

©2000 Fero Corporation

