

# CAN: PRESCRIPTIVE CORRUGATED STRIP TIE

# US: CORRUGATED SHEET-METAL ANCHOR

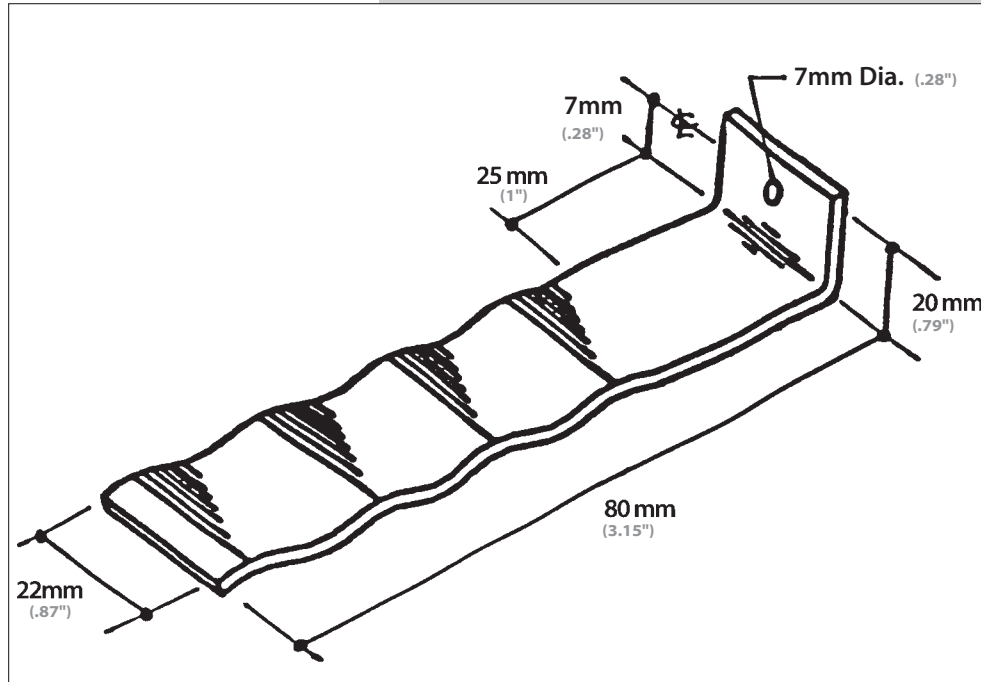
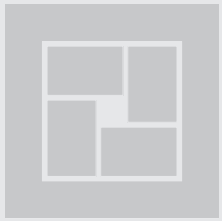

CORRUGATED  
STRIP TIE

## Introduction

The FERO Corrugated Strip is manufactured in strict compliance with the requirements of CSA A370-04, "Masonry Connectors"; and ACI 530/ASCE 5/TMS 402, "Building Code Requirements for Masonry Structures". It offers truly a compliance alternative for designers and contractors who are concerned about quality construction, and specifically choose not to use any of the plethora of non-compliant corrugated masonry veneer connectors currently sold on the market.

Design methods, compliance requirements, and terminology for corrugated strip ties/corrugated sheet-metal anchors differ between the respective codes and standards for Canada and United States. Design data are therefore reported separately herein.

<b>Plate thickness:</b>	<b>0.91 ± 0.05 mm</b> <b>(0.036" ± 0.002")</b>
<b>Wavelength of corrugations:</b>	<b>10 mm (0.39")</b>
<b>Depth of corrugations from crest to trough:</b>	<b>2.5 mm (0.1")</b>
<b>Distance from bottom of hole to bottom of tie:</b>	<b>5.25 mm (0.21")</b>
<b>Distance from centreline of hole to bottom of tie:</b>	<b>7 mm (0.28")</b>



Fero Corporation

15305 - 117 Avenue, Edmonton, Alberta T5M 3X4  
Phone: (780) 455-5098 Fax: (780) 452-5969  
www.ferocorp.com info@ferocorp.com

The FERRO Prescriptive Corrugated Strip Tie is manufactured from sheet steel having thickness  $0.91 \text{ mm} \pm 0.05 \text{ mm}$ , exceeding the minimum 0.8 mm base metal thickness required by CSA A370, "Masonry Connectors". It is available in both hot-dip galvanized finish and stainless steel. The weight of hot-dip galvanized finish is not less than  $460 \text{ g/m}^2/\text{side}$  ( $1.5 \text{ oz/ft}^2/\text{side}$ ), and satisfies the requirements of CSA A370 (which references ASTM A123).

The FERRO Prescriptive Corrugated Strip Tie complies with all requirements pertaining to the "prescriptive corrugated strip tie" prescribed by CSA A370-04, including material type and thickness, configuration, and level of corrosion protection.

## 1. Compliance with Canadian Codes and Standards:

- a. Requirements for the use, materials, configuration, level of corrosion protection, and methods of attachment for a corrugated strip tie differ between Part 9, and Parts 4/5 of the National Building Code of Canada (NBCC-05). The requirements under Part 4/5 are more onerous than those of Part 9. Corrugated strip ties intended specifically to satisfy the requirements of Part 9 design and construction do not comply with Part 4/5.
- b. Part 4/5 of NBCC-05 requires that masonry materials, design, and construction satisfy CSA S304.1-04. By way of reference to companion CSA masonry standards, CSA S304.1-04 requires that masonry connectors comply with CSA A370-04, "Masonry Connectors".
- c. The FERRO Prescriptive Corrugated Strip Tie:
  - i. satisfies the more restrictive requirements for a corrugated strip tie needed for compliance with Part 4/5 of the NBCC-05, and with CSA S304.1-04 and CSA A370-04;
  - ii. is intended for use with Part 4/5 construction, however, it may also be used for Part 9 construction where a superior strip tie is desired;
  - iii. may be used for masonry veneer designed using either of two compliance paths permitted under S304.1-04 and A370-04:
    1. prescriptive design; OR,
    2. engineered masonry design.

## 2. Design Requirements:

### a. Prescriptive Compliance Path:

Under the prescriptive compliance path for masonry veneer design:

- i. a prescriptive corrugated strip tie cannot be used under any of the following design conditions:
  1. where the 1 in 50-year reference velocity wind pressure "q" exceeds  $0.55 \text{ kN/m}^2$ ;
  2. where the seismic hazard index  $I_E F_a S_a(0.2)$  is equal to or greater than 0.35;
  3. where lateral loads other than wind loads (and the restricted seismic loads noted above) are applied to the ties, such as soil loads;
  4. where the exterior masonry veneer is constructed higher than 11 m above local grade; or,
  5. where the design width of an included air space is greater than 25 mm (and the constructed width is greater than 38 mm);
- ii. a prescriptive corrugated strip tie:
  1. must be fastened to wood frame structural backing using not less than a 6.1 mm diameter wood screw, embedded not less than 38 mm into the structural backing (excluding the thickness of any intervening sheathing);

2. must satisfy a spacing not exceeding:
  - a. 400 mm horizontal, 600 mm vertical; OR,
  - b. 600 mm horizontal, 400 mm vertical; AND
  - c. the reduced spacing at the veneer base, veneer top, and around openings required by CSA S304.1 and CSA A370;
3. cannot be bent or cut on-site (thereby requiring that the tie be pre-bent by the manufacturer, and hot-dip galvanized after fabrication);
4. cannot be fastened to other than wood frame construction unless the means of fastening is demonstrated to be equivalent to that otherwise required prescriptively by CSA A370 (and thus, use with other than wood frame construction requires the fastener to be designed in accordance with the engineered compliance path of S304.1-04 and A370-04);
5. must be embedded not less than 50 mm into the mortar bed of the masonry veneer.

b. Engineered Masonry Design:

A prescriptive corrugated strip tie may be used to tie masonry veneer systems that are rationally designed. Under the engineered masonry design compliance path, the limitations of the prescriptive compliance path (2.a, above) do not apply.

c. Level of Corrosion Protection:

A prescriptive corrugated strip tie:

- i. must satisfy the following levels of corrosion protection:
  1. where  $aDRI \leq 7$ , Level 2 (hot-dip galvanizing);
  2. where  $aDRI > 7$ , Level 3 (stainless steel);
- ii. must be fastened to the structural backing using a fastener having a level of corrosion protection not less than that of the prescriptive corrugated strip tie, and be chemically compatible to reduce the risk of galvanic corrosion.

## United States

The FERRO Corrugated Sheet-Metal Anchor is manufactured from sheet steel having thickness  $0.91 \text{ mm} \pm 0.05 \text{ mm}$ , exceeding the minimum 0.8 mm base metal thickness required by ACI 530/ASCE 5/TMS 402. "Building Code Requirements for Masonry Structures." It is available in both hot-dip galvanized finish and stainless steel. The weight of hot-dip galvanized finish is not less than  $460 \text{ g/m}^2/\text{side}$  ( $1.5 \text{ oz/ft}^2/\text{side}$ ), and satisfies the requirements of ACI 530.1/ASCE 6/TMS 602 (which references ASTM A153, Class B) and the International Codes (which reference ASTM A153, Class B).

The FERRO Corrugated Sheet-Metal Anchor complies with all requirements pertaining to the "corrugated sheet-metal anchor" prescribed by ACI 530/ASCE 5/TMS 402 and the International Codes including material type and thickness, configuration, and level of corrosion protection.

### 1. Compliance with U.S. Codes and Standards:

- a. Requirements for the use, materials, configuration, level of corrosion protection, and methods of attachment for a corrugated sheet-metal anchor do not differ between the International Codes and ACI 530/ASCE 5/TMS 402.
- b. By way of direct reference, the International Codes require the corrugated sheet-metal anchor to comply with ACI 530/ASCE 5/TMS 402.

- c. The FERO Corrugated Sheet-Metal Anchor:
  - i. satisfies all requirements for the corrugated sheet-metal anchor contained in the international Codes and in ACI 530/ASCE 5/TMS 402;
  - ii. may be used for masonry veneer anchored to wood backing or other structural backing, designed using either of two compliance paths permitted under ACI 530/ASCE 5/TMS 402:
    - 1. prescriptive design; OR,
    - 2. rational design (alternative design).

## 2. Design Requirements:

### a. Prescriptive Compliance Path:

Under the prescriptive compliance path for masonry veneer design:

- i. a corrugated sheet metal anchor may be used under the following design conditions:
  - 1. where the structural backing is wood;
  - 2. where the height of the masonry veneer above a wood foundation does not exceed 18' (5.5 m);
  - 3. where the height of the masonry above the foundation does not exceed 30' (9.15 m) at the plate, or 38' (11.6 m) at the gable, and the masonry veneer is supported on non-combustible structural supports such as concrete or masonry;
  - 4. where the distance between the inside face of the veneer and outside face of the supporting structural backing is not greater than 1" (25 mm);
- ii. a corrugated sheet-metal anchor:
  - 1. must be fastened to wood frame structural backing using not less than a corrosion resistant 8d common nail or equivalent;
  - 2. must extend into the veneer a minimum of 1-1/2" (38 mm);
  - 3. in Seismic Design Categories A, B, and C, must satisfy a spacing not exceeding:
    - a. 32" (813 mm) horizontally and 25" (635 mm) vertically; AND,
    - b. 2.67 ft<sup>2</sup> (0.25 m<sup>2</sup>), AND,
    - c. the spacing around openings required by ACI 530/ASCE 5/TMS 402;
  - 4. in Seismic Design Categories D, E, and F, must satisfy a spacing not exceeding:
    - a. 32" (813 mm) horizontally and 25" (635 mm) vertically; AND,
    - b. 2.00 ft<sup>2</sup> (0.19 m<sup>2</sup>); AND,
    - c. the spacing around openings required by ACI 530/ASCE 5/TMS 402;
  - 5. in areas of high winds:
    - a. where the basic wind speed exceeds 110 mph (177 km/hr) as given in ASCE 7 but does not exceed 130 mph (209 km/hr), must satisfy a spacing not exceeding:
      - a. 18" (450 mm) horizontally and 18" (450 mm) vertically; AND,
      - b. 1.87 ft<sup>2</sup> (0.17 m<sup>2</sup>), AND,
      - c. the spacing around openings required by ACI 530/ASCE 5/TMS 402.

### b. Engineered Masonry Design:

A corrugated sheet-metal anchor may be used to anchor masonry veneer systems that are rationally designed. Under the alternative design compliance path, the limitations of the prescriptive compliance path (2.a, above) do not apply.



**Fero Corporation**

15305 - 117 Avenue, Edmonton, Alberta T5M 3X4  
 Phone: (780) 455-5098 Fax: (780) 452-5969  
[www.ferocorp.com](http://www.ferocorp.com) [info@ferocorp.com](mailto:info@ferocorp.com)